

PI-Controller; PA-plug housing acc. to DIN 43650 A; 24 VDC



Advantages / Benefits

- ▶ "Ready-to-use" automation module
- ▶ 80% less planning and installation costs
- ▶ On-the-spot easy installation, configuration and operation
- ▶ Fixed and variable set-points
- ▶ Controller fully functional without removable control-unit
- ▶ CE conform

Design/Function

The electronic PI-controller is integrated in a polyamid plug housing acc. to DIN 43 650 A to be plugged directly on a continuous control valve (i.e. Burkert types 6022, 6023, 6223).

It comprises two basic elements: the microprocessor controlled self-supporting and programmable controller and the removable control unit type 1077-7, which can be utilized for more than one controller.

The controller can be used to control mixing temperature of liquids. A frequency-analog input for a temperature sensor (i.e. Burkert temperature sensor type ST20, ST21) is available to be compared with a process set-point, which can be preset internally through push buttons or externally through a standard signal.

The removable control-unit has a display and two push buttons for:

- heating and cooling
- setting the control parameters
- configuring the set-point
- monitoring the process values

Application example:
Control of a mixed temperature

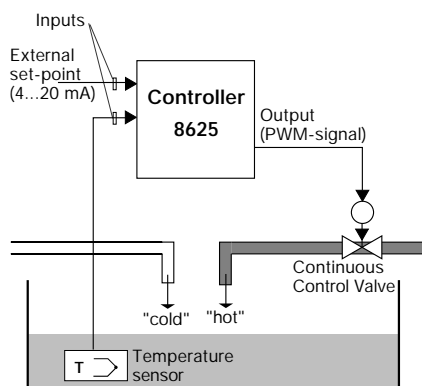

Basic demand: required mixed temperature is between "cold" and "hot"

Applications

- Control of water temperature in showers and tanks
- Temperature controlled cooling circulations in machines and robots
- Temperature control in process technologies of chemical plants
- Temperature control in water treatment and in medical equipment
- Temperature controlled supply of gases and liquids



Compact Plug-on Temperature Controller

Type 8625

Technical Data

Operating voltage:	24 V/DC	LCD-display of control-unit 1077-6:	4 1/2 - digit 7-segment display
Power consumption:	max. 1.5 W	Outputs	
Inputs		Output signal:	electr. PWM-signal (pulse-width-modulation) max. 1.0 A
Sensor input:	Pt100 input	Output current:	Integrated plug-in module acc. to DIN 43 650 A
External set-point:	Standard signal 4 ... 20 mA	Electr. connection:	2-pole with ground in 4 x 90 steps
Temperature range:	-100 °C ... +500 °C	Rating (plugged-in):	IP 65
Calibration in 50° steps:	Resolution 0.3 °C accuracy 1 °C	Operating temperature:	-10 °C ... +60 °C
Calibration in 100° steps:	Resolution 0.5 °C accuracy 1.5 °C	Housing material:	Polyamide (PA)
Electric connection:	In unit: 7 pole terminal + PE Cable ø 6-7 mm Wire cross-section max. 0.5 mm ² PG9 fitting	Mounting:	M3x45 mm cheesehead screw
Programming: (with control-unit type 1077-7 ¹⁾)	- Heating and cooling - Setting of control parameter - Configuration of set-point - Monitoring of process values	Installation:	as required
		Weight:	approx. 50 g

¹⁾ The control-unit type 1077-7 is not included in the delivery of type 8625 compact temperature controller

Dimensions [mm]

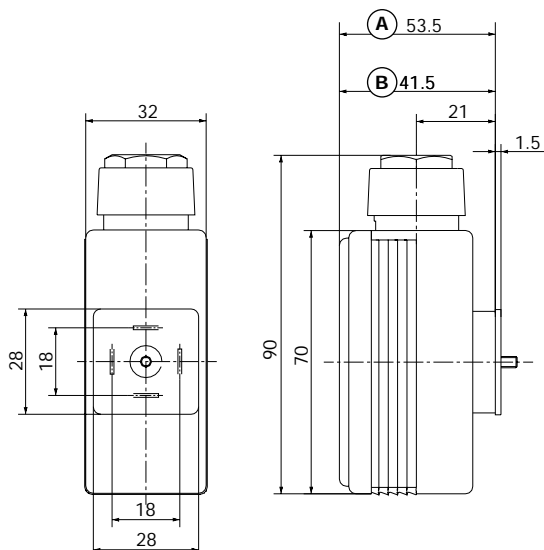

- A** Dimension with plugged-in control unit
(not included in delivery of type 8625)
- B** Dimension with protection cover (included in delivery),
without control-unit

Remark:

When screwing the temperature controller to the valve, ensure that the seal is properly seated.

Ordering Chart

Type	Item-No.
Temperature Controller 8625	134 074 M
Temperature Control-Unit 1077-7	134 054 R

