

PI-Controller; PA-Plug Housing acc. to DIN 43650 A; 24 VDC

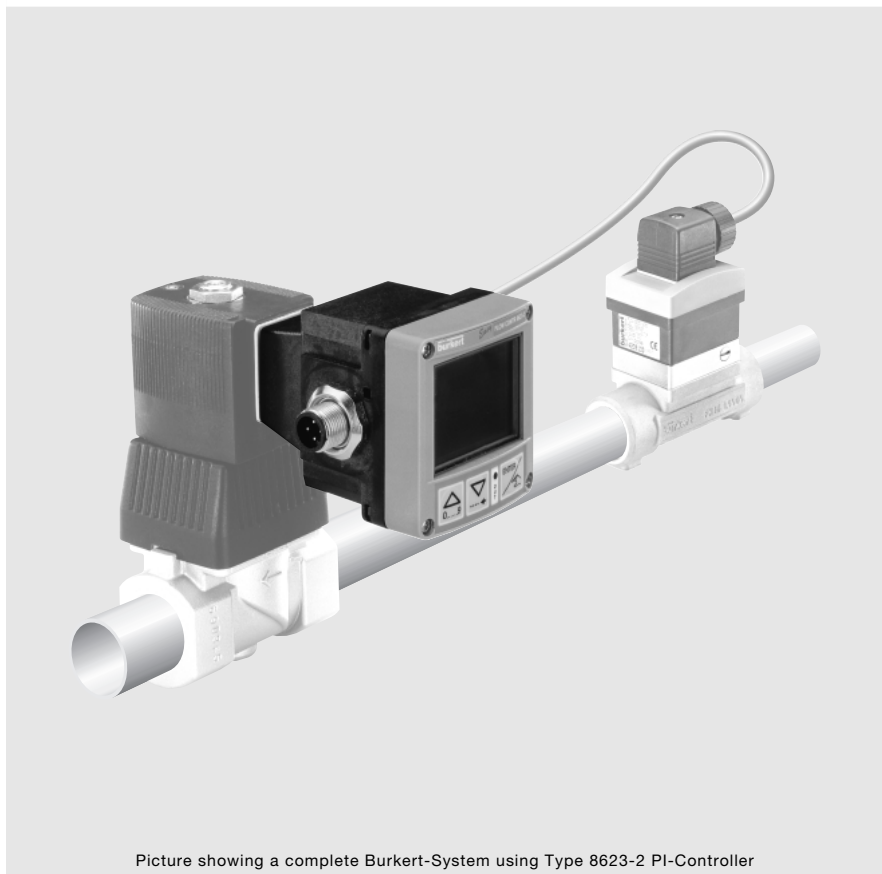

Picture showing a complete Burkert-System using Type 8623-2 PI-Controller

Advantages / Benefits

- 

▶ Up to 80% lower Total Cost of Ownership
- 

▶ Easy and fast installation, configuration and operation
- 

▶ Internal and external setpoint for easy networking and easy customizing
- 

▶ High reliability of process, thanks to decentralized intelligence

Design / Function

This PI-controller allows to setup a closed loop control for controlling flow or mixing ratios. It can be combined with a solenoid control valve (i.e. 6022, 6023, 6223 and 2832, 2834, 2836) and a flow sensor with frequency signal (i.e. 8020, 8030 or 8040).

The setpoint can be programmed not only manually, but also from an external PLC or other process controller.

The PI-controller can be used to control not only flow, but also the mixing ratios of liquids. In the latter case, the two frequency inputs from the flow sensors of the controlled and uncontrolled flow are constantly compared to the programmable flow ratio and its setpoint.

Flexibility to the process is given by many different features, such as scaling, programming of process control parameters, setting of the external or internal setpoints as well as by monitoring the process value on the display.

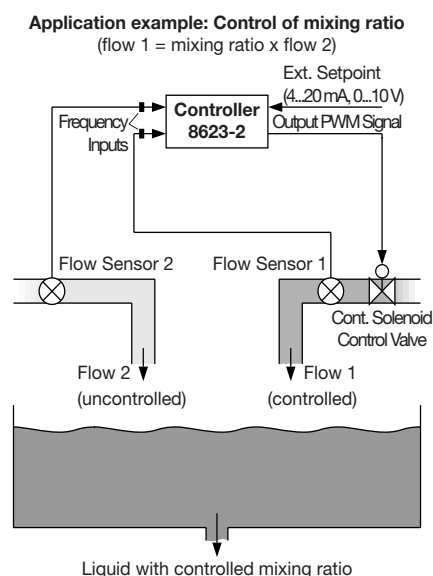

Applications

- Control of supply of liquids in chemical process engineering
- Control of flow in water cooling circuits in machines and plants
- Control of mixing ratios of liquids
- Control of liquid supply in water treatment
- Control of damping in paper and textile machineries
- Control of flow in batch machines



## Technical Data

Operating voltage	24 V DC	LCD-display	4 digit numeric display 4 letter text display
Power consumption	Max. 1.5 W		
<b>INPUTS</b>		<b>OUTPUTS</b>	
Sensor	2 Frequency inputs (2 to 1000 Hz)	Outputs to valve	
Accuracy	± 1%	Output signal	electr. PWM-signal (pulse-width-modulation)
Type of signals	Frequency Sinusoidal, square wave, triangular ( $\geq 300 \text{ m V}_{SS}$ )	Output current	max. 1.0 A
External setpoint	Standard signal 4...20 mA or 0...10 V	Electr. connection to valve	Plug-on acc. to DIN 43 650 A (secured with a screw) Can be mounted in rotational increments of 90°
Resolution	10 Bit	Rating (plugged-on)	IP 65
Electrical connections to Sensors	2 Male connectors M8 (3 pins each)	Ambient temperature	-10 °C ... +60 °C
Power supply and external setpoint	1 Male connector M12 (4 pins)	Housing material	Polyamide (PA)
Programming	-Setting of K-factor -Setting of control parameter PI -Configuration of setpoint -Monitoring of process values	Weight	approx. 130 g

## Ordering Chart

Type:	Item-No.:
Flow Controller 8623-2	143 569 B

## Ordering Chart Accessories (Cables and Connectors)

Description / Feature:	Connecting PI-Controller with:	Item-No.:
Connector M12 with 5.0 m cable (4 wire)	Power supply / External setpoint	918 038 T
Connector M8 with 2.0 m cable (3 wire)	-	918 039 U

## Dimensions [mm]

