

2/2-Way; servo-assisted; G 3/8" - G 1"; PN 0,5-10 bar



**Advantages / Benefits**

- ▶ Optimization of process and product quality through continuous regulation
- ▶ Increase of efficiency
- ▶ Extremely high control accuracy:
  - low hysteresis
  - high repeatability
  - high responsivity
- ▶ Particularly good turn down ratio and thereby usage of an optimal control range
- ▶ Fail safe (self-closing in case of power failure)
- ▶ A complete control system "all from one" with Burkert sensors and controllers

**Design / Function**

Type 6223 is a servo-assisted solenoid control valve for  $K_{vs}$  flow rates from 1.4 to 5 m<sup>3</sup>/h. The variable opening of the cross-section is continually changed proportional to the standard electrical input signal. The characteristic curve of the valve is practically linear; regulation deviations are extremely low. With < 1%, the valve has a high sensitivity, due to a higher frequent pulse-width modulation. The solenoid control valve consists of the basic components of armature, push-over coil and electronic control unit, and can be mounted in any position. The electronic control unit is integrated into the DIN 43650A cable plug, but can also be supplied as a standard DIN-rail mounting version.

- Adjustable ramp function from 0-10 s cushions set-point jumps
- Standard input signals 4-20 mA, 0-10V
- Monitor signal to assist set-up and indication of coil current
- Tight shut-off due to zero-point suppression
- Compensation of the coil heating
- Start of opening and max. opening adjustable
- Simple ordering procedure with one order number for valve and control electronics

**Applications**

- Continuous control of larger flow rates of neutral media.
- General machine construction (in particular control for cooling circulations)
  - Process technology in the chemical industry
  - Paper and printing machines (e.g., damp control)
  - Filling systems
  - Machinery and plants for food and beverage industries
  - Water treatment
  - Medical technology (sterilization)
  - Textile industry (dyeing, washing, drying)



## Technical data

### Valve function

A 2/2-way flow valve, normally closed, servo-assisted

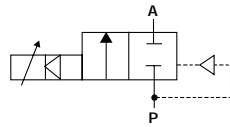

### Function of control electronics

- Temperature compensation for coil heating by internal current control
- Ramp function to dampen fast status changes
- Simple adaptation of the start of opening and of the reaching of maximum flow rate to the pressure conditions of the respective application by means of two potentiometers.
- Monitor function with LED display

### Operational data (Armature)

Pressure range	0.5 - 10 bar
Port connection	G 3/8", 1/2", 3/4", 1" (see characteristics)
Body material	Brass
Sealing material	FPM (Viton)
Medium	Neutral liquids (Air and gases on request)
Temperat. range of medium	-10 ... +90°C
Max. ambient temperature	+55°C
Max. Viscosity	21 cSt
Installation position	Any, no limitation on function

### Operational data for Control Electronics

Design version M	Plug-on module
Design version H	DIN-rail mounting version (on request)
Operational voltage	DC 24 V/±, (max. 28V/±)
Ripple	±10% (We recommend power supply type 1610)
Input signal	4-20 mA, 0-10V (0 - 20mA on request)
Control signal for valve	PWM (Pulse Width Modul.)
Max. current consumption	1.1A
Power	max. 0.5 W
Monitoring signal	Directly proportional to coil current 1 mV = 1 mA as set-up aid, or for external display.
Ramp time	0 - 10s (adjustable)
Protection class	IP65 (when mounted on valve, version M)
Electrical connection	Screw terminals for ø7 mm cable

### Operational data (Solenoid)

Operational voltage	DC 24 V/±
Nominal power	See characteristics
Duty cycle	100% continuously rated
Protection class with mounted plug-on module	IP 65

## Materials

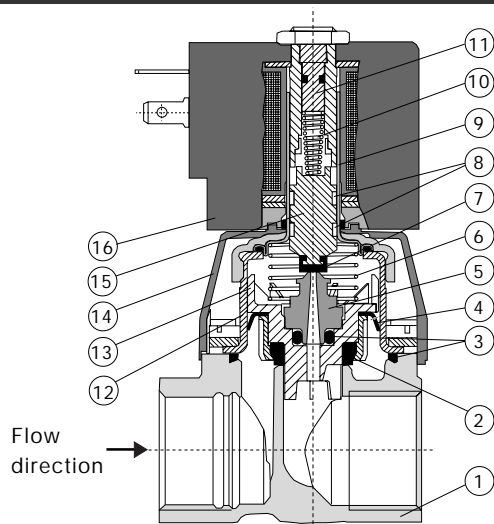

1 Valve body:	Brass
2 Seal:	FPM
3 O-rings:	FPM
4 Gasket:	PTFE
5 Pilot-seat:	PPS
6 Spring:	1.4310
7 Plunger-seal:	FPM
8 Slip-ring:	PTFE-Compound
9 Armature guide tube:	1.4301
10 Spring:	1.4310
11 Stopper:	1.4105
12 Cover:	1.4301
13 Piston:	PPS
14 Bonnet:	PA (Polyamide)
15 Plunger:	1.4105
16 Coil bobbin:	PA (Polyamide)

**Characteristic Values with Ordering Information (other versions on request)**

**Brass body; Sealing FPM**

(with plug-on control electronics)

Port-connection [Inch]	Orifice [mm]	$K_{Vs}$ -Value (Water) [m <sup>3</sup> /h]	$Q_{Nn}$ -Value <sup>1)</sup> (Air) [l/min]	Pressure-range <sup>2)</sup> [bar]	Power-consumption [W]	max. Coil-current [mA]	Input-signal <sup>3)</sup>	Weight [kg]	Order-No.
G 3/8	10,0	1,4	1500	0,5 - 10	8	300	4...20 mA	0,522	702 515 W
G 3/8	10,0	1,4	1500	0,5 - 10	8	300	0...10 V	0,522	702 516 X
G 1/2	10,0	1,4	1500	0,5 - 10	8	300	4...20 mA	0,488	702 517 Y
G 1/2	10,0	1,4	1500	0,5 - 10	8	300	0...10 V	0,488	702 518 H
G 1/2	13,0	2,5	2700	0,5 - 10	10	330	4...20 mA	0,744	702 519 A
G 1/2	13,0	2,5	2700	0,5 - 10	10	330	0...10 V	0,744	702 520 F
G 3/4	13,0	2,5	2700	0,5 - 10	10	330	4...20 mA	0,655	702 521 U
G 3/4	13,0	2,5	2700	0,5 - 10	10	330	0...10 V	0,655	702 526 Z
G 3/4	20,0	5,0	5400	0,5 - 10	15	530	4...20 mA	1,403	702 527 S
G 3/4	20,0	5,0	5400	0,5 - 10	15	530	0...10 V	1,403	702 528 B
G 1	20,0	5,0	5400	0,5 - 10	15	530	4...20 mA	1,270	702 529 C
G 1	20,0	5,0	5400	0,5 - 10	15	530	0...10 V	1,270	702 530 H

1) Versions for air and gases on request.

2) All pressures quoted are gauge pressures with respect to the prevailing atmospheric pressure.

3) Input signal 0-20 mA on request.

**Regulation data - characteristics**

Characteristic	see diagram
Hysteresis	< 5%
Repeatability	< 1% F.S.
Responsivity	< 1% F.S.
Setting time (90%)	< 200 ms
Turn down ratio	1 : 20

**Advice for selection of valve sizing**

In fluid plants including continuous valves, the choice of the appropriate valve size is much more important than with on/off valves. The optimum orifice should be selected such that, on the one hand, the resulting flow in the fluid system is not unnecessarily reduced by the valve, and, on the other hand, a sufficient part of the pressure drop takes place over the valve even if it is fully opened:

**recommended value:  $\Delta p_{\text{valve}} > 30\%$  of total  $\Delta p$  within the system**

Otherwise, even a perfectly linear valve characteristic will be deformed to a heavily convex shape. For that reason, Burkert offers a competent guide service from the early planning phases of a fluid plant.

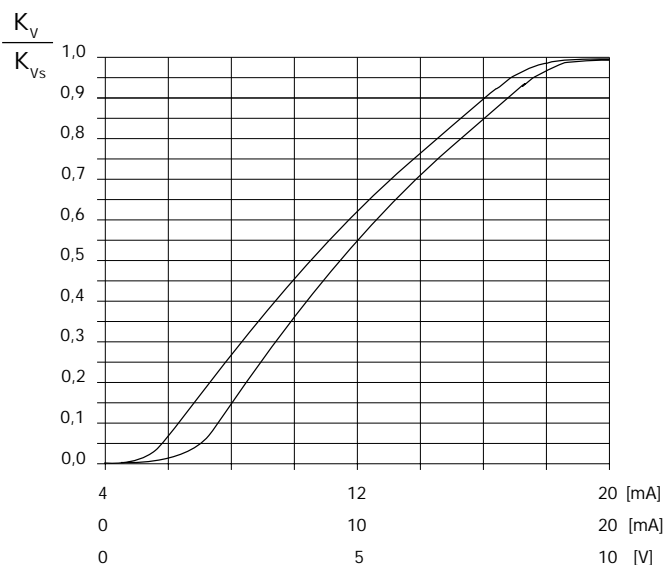

Dimensions (in mm)

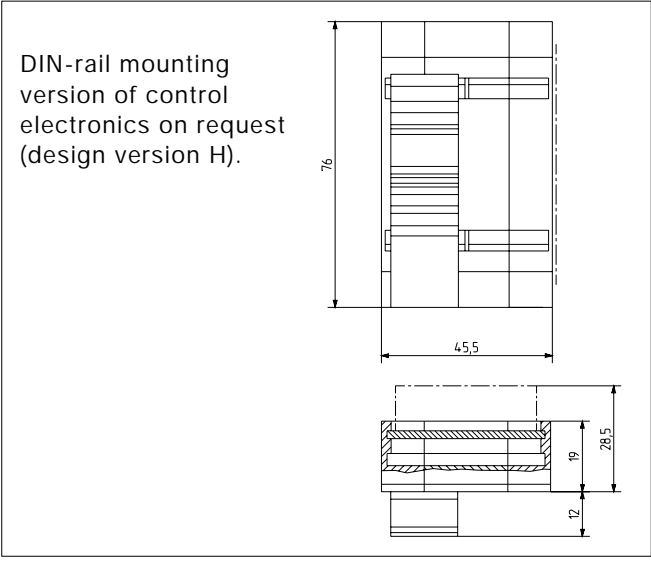
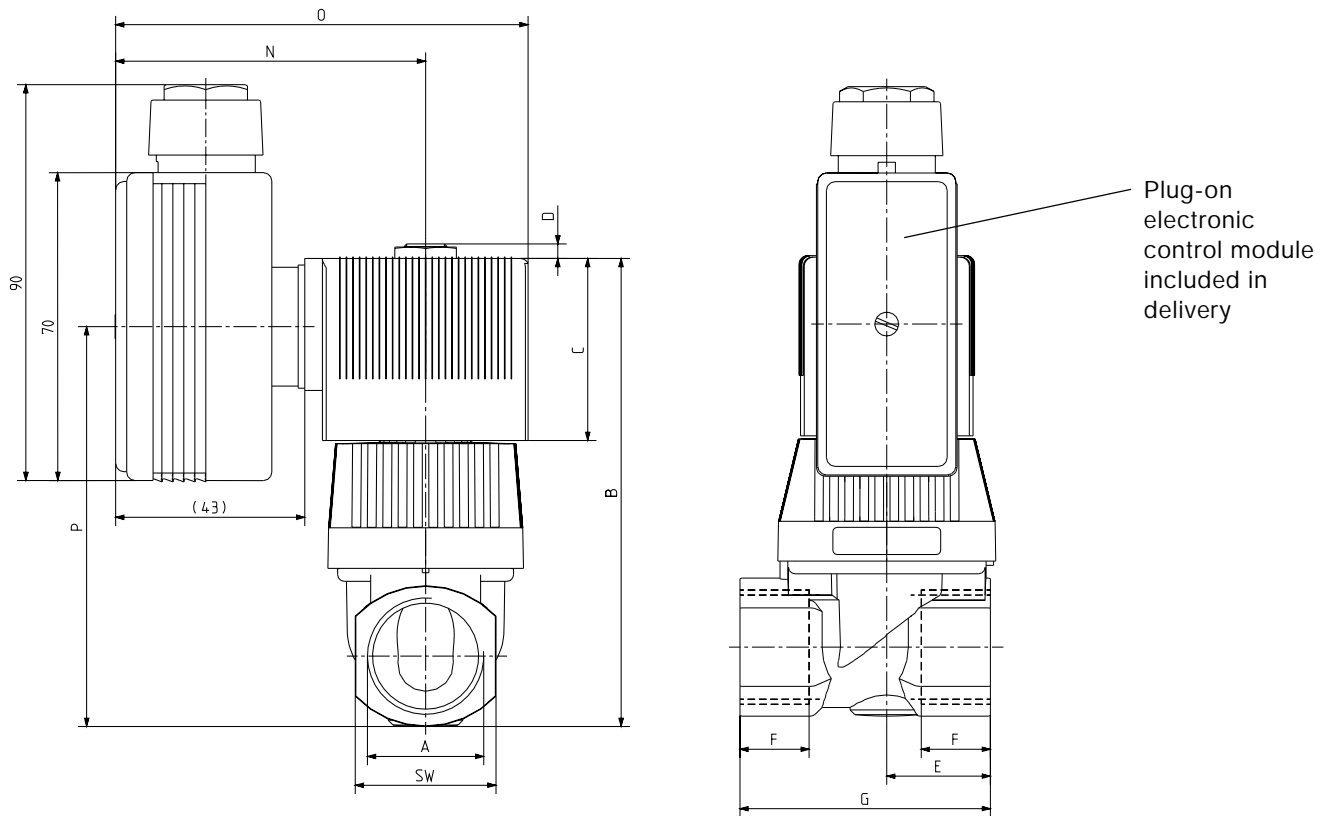

Port-connection A	Orifice [mm]	SW	B	C	D	E	F	G	H	I	K	L	M	N	O	P
G 3/8	10	27	85,5	41,0	3,7	20,0	12,0	50,0	32,0	38,0	37,5	20,5	45,0	67,5	88,0	70,4
G 1/2	10	27	85,5	41,0	3,7	20,0	14,0	50,0	32,0	38,0	37,5	20,5	45,0	67,5	88,0	70,4
G 1/2	13	32	106,2	41,4	3,3	24,0	14,0	58,0	40,0	50,5	44,5	23,5	51,0	70,5	94,0	90,7
G 3/4	13	32	106,2	41,4	3,3	24,0	16,0	58,0	40,0	50,5	44,5	23,5	51,0	70,5	94,0	90,7
G 3/4	20	41	147,6	64,0	7,0	35,0	16,0	80,0	43,0	66,0	66,0	21,5	50,0	71,5	93,0	122,8
G 1	20	41	147,6	64,0	7,0	35,0	18,0	80,0	43,0	66,0	66,0	21,5	50,0	71,5	93,0	122,8

In case of special requirements, please advice for consults.

We reserve the right to make technical changes without notice.

710-GB/ 2-0035