

3/2-Way; G 1/8 bis 1/4"; PN up to 16 bar



### Advantages/Benefits

- ▶ Coil can be changed easy with valve in place
- ▶ Coil can be locked in 4x 90° positions or move freely between, as required
- ▶ Medium is only in contact with the valve internals and body
- ▶ High-quality seal material FPM (Viton) standard
- ▶ Wide range of cable plug options Type 2508

### Design/Functions

The valves are based on a modular concept comprising three basic elements; Valve assembly, push-over coil and standard cable plug. The valve assembly consists of a body to which the armature guide tube containing the plunger, seals and springs is attached. The coil is pushed over the guide tube and thus isolated from the medium. The medium is only in contact with the valve internals and body.

A wide selection of pipe and orifice sizes is offered. Valves are available in brass or stainless steel. All valves have high quality viton (FPM) seals as standard.

To simplify ordering, a wide selection of standard combinations of valve body, push over coil and standard cable plug can be ordered with one order number.

Cable plug options of Type 2508 are available to suit special electrical application requirements.

- The modular concept provides flexibility to meet applications requirements.
- The valve are interchangeable with Type 311.

### Applications

#### Fluids

Brass version: Neutral gases and liquids, e.g.compressed air, town gas, natural gas, water, hydraulic oil, petrol.  
Stainless steel version: Difficult and slightly aggressive media

Suitable for technical vacuum

#### Applications

- Pneumatic control
- Shut-off, dosing, filling and ventilating
- Small-scale instruments, laboratory and measuring technology
- Welding technology

**bürkert**  
Easy Fluid Control Systems

## Technical Data Type 6014

### Circuit function

**C** 3/2-way valve,  
when de-energized, outlet A  
pressure relieved

### Symbol

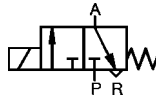

**D** 3/2-way valve,  
when de-energized, outlet B  
pressurized

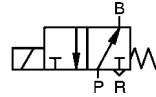

### Circuit function

**T** Universal mixer or distributor valve,  
when de-energized R ↔ A open  
and P ↔ A closed,  
for universal use

### Symbol

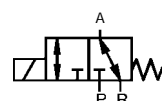

## Operating Data (Valve)

Pressure range	0-16 bar (see specifications)
Port connection	Threaded port G 1/8" - G 1/4"
Orifice	DN 1,5-2,5 mm
Fluid	Neutral gases and liquids, e.g. compressed air, town gas, natural gas, water, hydraulic oil, petrol. Stainless steel version: Difficult and slightly aggressive media. Suitable for techn. vacuum.
Medium temperature	-10 bis +100 °C
Max. ambient temperature	+55 °C
Max. viscosity	21 mm <sup>2</sup> /s
Response times opening closing	AC 10-15 ms; DC 15-20 ms AC 15-20 ms; DC 10-22 ms
Installation	as required, but preferably with solenoid system upright

## Operating Data (Actuator)

Operating voltages	AC 24, 110, 230 V/50 Hz, DC 12, 24 V/=						
Voltage tolerance	±10 %						
Power consumption 32 mm-coil	<table border="1"> <tr> <th>AC inrush</th> <th>AC hold</th> <th>DC</th> </tr> <tr> <td>24 VA</td> <td>17 VA/8 W</td> <td>8 W</td> </tr> </table>	AC inrush	AC hold	DC	24 VA	17 VA/8 W	8 W
AC inrush	AC hold	DC					
24 VA	17 VA/8 W	8 W					
Duty cycle Duty cycle for multiple manifolds	100% continuously rated 60% for manifold mounting (30 min) or use 5W-version (on request)						
Cycling rate	up to 1 200 c.p.m.						
Rating with cable plug	IP 65						
Electr. connection	Delivery standard: Cable plug DIN 43 650 A, 0-250 V(other versions see accessories)						

## Materials

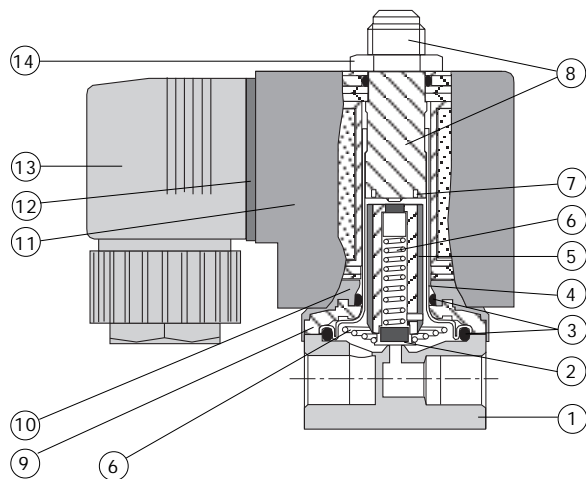

1 Valve body:	Brass, S.Steel 1.4305 (G1/8") S.Steel 1.4401 (G1/4")
2 Plunger-seal:	FPM (Viton)
3 O-rings:	FPM (Viton)
4 Armature guide tube:	1.4303
5 Plunger:	1.4105
6 Spring:	1.4310
7 Shading ring:	Cu (brass version) Ag (stainless steel version)
8 Stopper:	1.4105
9 Flange:	Zn3 gl cC (surface)
10 Bonnet:	Durethan BKV30H
11 Coil:	PA (Polyamide)
12 Flat seal:	NBR
13 Cable plug:	PA (Polyamide)
14 Locknut:	9SMnPb28K (surface Zn5glcA)

## Specifications - Ordering Chart (Other Versions on Request)

Type 6014; brass body (MS); coil 8 W;

(with standard-cable plug 0-250 V AC/DC)

Circuit function <sup>1)</sup>	Orifice [mm]	Kv-value water <sup>2)</sup> [m <sup>3</sup> /h]	Pressure range <sup>3)</sup> [bar]	Port connection	Voltage/frequency [V/Hz]	Weight [g]	Order-No. (ohne Handbetätigung)	Bestell-Nr. (mit Handbetätigung)
C	1,5	0,07	0-16	G 1/8	24/=	365	125 329 Y	
					24/50		125 331 J	
					110/50		126 137 H	
					230/50		125 332 K	
C	2,0	0,11	0-10	G 1/8	24/=	365	125 333 L	125 337 Q
					24/50		125 334 M	125 338 Z
					110/50		125 335 N	126 146 J
					230/50		125 336 P	125 339 S
C	2,0	0,11	0-10	G 1/4	24/=	465	125 348 B	125 349 C
					24/50		126 138 J	126 147 K
					110/50		126 139 K	126 148 U
					230/50		126 140 Y	126 149 V
C	2,5	0,16	0- 6	G 1/8	24/=	365	125 341 U	
					24/50		125 340 F	
					110/50		126 141 M	
					230/50		125 342 V	
C	2,5	0,16	0- 6	G 1/4	24/=	465	126 142 N	
					24/50		126 143 P	
					110/50		126 144 Q	
					230/50		126 145 R	
D	1,5	0,07	0-16	G 1/8	24/=	365	126 195 C	
					24/50		126 196 D	
					110/50		126 197 E	
					230/50		125 355 S	
D	2,0	0,11	0-10	G 1/8	24/=	365	125 357 U	126 209 A
					24/50		125 358 D	125 361 Y
					110/50		125 359 E	126 210 W
					230/50		125 360 B	126 211 K
D	2,0	0,11	0-10	G 1/4	24/=	465	126 198 P	126 212 L
					24/50		126 199 Q	126 213 M
					110/50		126 200 D	126 214 N
					230/50		126 201 S	126 215 P
D	2,5	0,16	0- 6	G 1/8	24/=	365	125 363 S	
					24/50		126 202 T	
					110/50		126 203 U	
					230/50		126 204 V	
D	2,5	0,16	0- 6	G 1/4	24/=	465	126 205 W	
					24/50		126 206 X	
					110/50		126 207 Y	
					230/50		126 208 H	
T	1,5	0,07	0- 6	G 1/8	24/=	365	126 150 S	
					24/50		126 151 P	
					110/50		126 152 Q	
					230/50		126 153 R	

<sup>1)</sup> To use valves in other operations than specified, will change the specified maximum pressure range. Special applications on request.

<sup>2)</sup> Measured with 6 bar upstream pressure and 1 bar pressure drop across the valve at +20 °C.

<sup>3)</sup> All pressures quoted are gauge pressures with respect to the prevailing atmospheric pressure.

### Specifications - Ordering Chart (Other Versions on Request)

**Type 6014; stainless steel body (VA); coil 8W;**

(with standard-cable plug 0-250 V AC/DC)

Circuit function <sup>1)</sup>	Orifice [mm]	Kv-value water <sup>2)</sup> [m <sup>3</sup> /h]	Pressure range <sup>3)</sup> [bar]	Port connection	Voltage/frequency [V/Hz]	Weight [g]	Order-No. (without manual override)	Order-No. (with manual override)
C	1,5	0,07	0-16	G 1/8	24/=	340	126 216 Q	
					24/50		126 217 R	
					110/50		126 218 S	
					230/50		126 219 T	
C	2,0	0,11	0-10	G 1/8	24/=	340	126 220 Y	
					24/50		126 221 M	
					110/50		126 222 N	
					230/50		126 223 P	
C	2,0	0,11	0-10	G 1/4	24/=	445	126 224 Q	
					24/50		126 225 R	
					110/50		126 226 J	
					230/50		126 227 K	
T	1,5	0,07	0- 6	G 1/8	24/=	340	126 228 U	
					24/50		126 229 V	
					110/50		126 230 S	
					230/50		126 231 P	

<sup>1)</sup> To use valves in other operations than specified, will change the specified maximum pressure range. Special applications on request.

<sup>2)</sup> Measured with 6 bar upstream pressure and 1 bar pressure drop across the valve at +20 °C.

<sup>3)</sup> All pressures quoted are gauge pressures with respect to the prevailing atmospheric pressure.

### Dimensions Type 6014 (in mm)

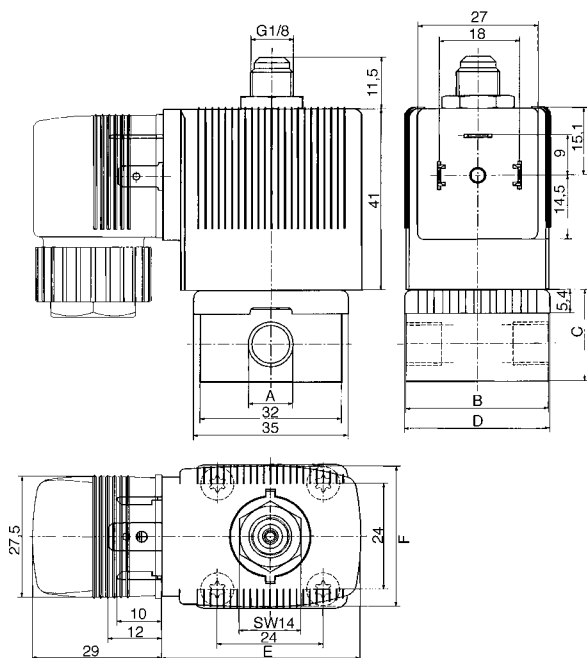

### Variable Dimensions

	Armature				Coil	
	A	B	C	D	E	F
Threaded Port G without manual override	1/8	32	20,8	32,6	45	32
Threaded Port G with manual override	1/4	46	26,8	49,0	45	32

### Dimensions Accessories (in mm)

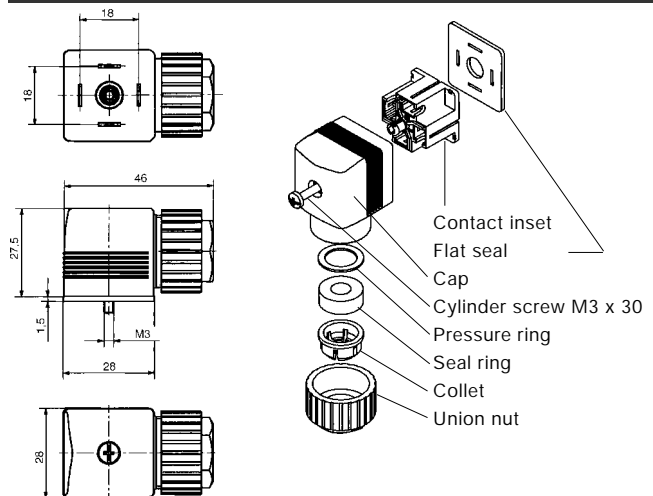

### Ordering Chart Accessories

Accessory	Features	Order-No.
<b>Cable-plugs<sup>1)</sup></b> Type 2508	Standard cable plug, 0-250 V AC/DC (standard-delivery) <sup>1)</sup>	008 376 N
	with LED, 12-24 V AC/DC	008 360 S
	with LED, 100-120 V AC/DC	008 361 P
	with LED + Varistor, 12-24 V AC/DC	008 367 M
	with LED + Varistor, 100-120 V AC/DC	008 368 W
	with LED + Varistor, 200-240 V AC/DC	008 369 X

<sup>1)</sup> The standard cable plug (0-250 V AC/DC), Order-No. 008 376 N is part of the standard delivery. Ordering of optional cable plugs with separate ordering number.

A wide selection of further cable plugs is available (see special data sheet Type 2508)