

Compact Solenoid Valve Threaded Port G 1/8 – G 1/4; Sub-base Connection

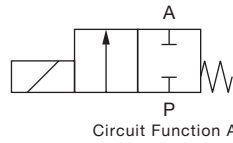

6013 Ex



2/2-Way; PN up to 10 bar

- ✓ **EEx m II T4 or EEx me II T4 approved**
- ✓ **Coil lockable in 4 x 90° positions or freely movable in between, as required**
- ✓ **High-quality seal material FPM (Viton) as standard**

Hazardous Areas

6013
Ex

The valves are based on a modular concept comprising two basic elements: Valve body and push-over coil with moulded-in cable or with terminal box.
The valve body consists of a body to which the armature guide tube containing the plunger, seals and springs is attached.
The coil is pushed over the guide tube and thus isolated from the medium.
The medium is only in contact with the valve internals and body.
Valves are available in polyamide, brass or stainless steel, all with high quality FPM (Viton) seals as standard.

Operating Data – Valve

Pressure range	0 – 10 bar (see specifications)
Port Connections	Threaded port G 1/8" – G 1/4" or Sub-base connection
Orifice	DN 2.0 up to 6.0 mm
Fluids	<ul style="list-style-type: none"> • Neutral gases and liquids, e.g. compressed air, town gas, natural gas, water, hydraulic oil and petrol • Difficult and slightly aggressive media • Suitable for technical vacuum
Brass	
Stainless Steel	
Temperatures	
Medium	-10 up to +90°C
Ambient	-30 up to +60°C
Max. viscosity	21 mm ² /s
Response times	
Opening	AC, DC 20 ms
Closing	AC, DC 30 ms
Installation	As required, but preferably with solenoid system upright

Operating Data – Actuator

Operating voltages	24, 110, 230 V/UC
Voltage tolerance	±10%
Duty cycle	100% continuously rated
Cycling rate	up to 1'000 c.p.m.
Rating	IP65
Approvals	<ul style="list-style-type: none"> • EEx m II T4 with moulded cable • EEx me II T4 with terminal box

- Applications:**
- Chemical industry
 - Pharmaceutical processing equipment
 - Industrial waste water treatment
 - Oil and gas industry

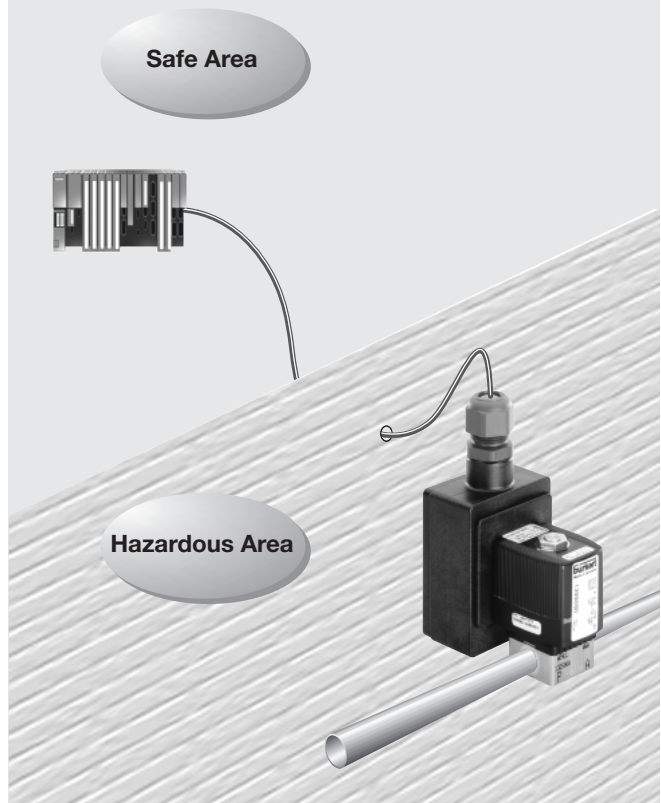

Compact Solenoid Valve Threaded Port G 1/8 – G 1/4; Sub-base Connection



Specifications - Ordering Chart (Other Versions on Request)

EEx m II T4 approved

Seal material FPM, moulded cable (3 m), single mounting only, without manual override

Circuit function	Orifice DN [mm]	Port connection [inch]	Kv-Value (water) [m³/h]	Power consumption [W]	Pressure range [bar]	Voltage/Frequency [V/Hz]	Item-No. Body material	
							Brass	Stainless Steel
A	2.0	Sub-base	0.11	7	0 – 6.0	24/UC	139 895 P	–
A	2.0	Sub-base	0.11	7	0 – 6.0	230/UC	139 896 Q	–
A	2.0	G 1/8	0.12	9	0 – 10.0	24/UC	136 039 L	136 027 G
A	2.0	G 1/8	0.12	9	0 – 10.0	110/UC	136 040 Z	136 028 R
A	2.0	G 1/8	0.12	9	0 – 10.0	230/UC	136 041 N	136 029 J
A	2.0	G 1/4	0.12	9	0 – 10.0	24/UC	139 892 L	139 887 P
A	2.0	G 1/4	0.12	9	0 – 10.0	110/UC	139 893 M	139 888 Y
A	2.0	G 1/4	0.12	9	0 – 10.0	230/UC	139 894 N	139 889 Z
A	2.5	G 1/8	0.16	9	0 – 8.0	24/UC	136 042 P	–
A	2.5	G 1/8	0.16	9	0 – 8.0	110/UC	136 043 Q	–
A	2.5	G 1/8	0.16	9	0 – 8.0	230/UC	136 044 R	–
A	3.0	G 1/8	0.23	9	0 – 5.0	24/UC	136 045 J	136 030 P
A	3.0	G 1/8	0.23	9	0 – 5.0	110/UC	136 046 K	136 031 C
A	3.0	G 1/8	0.23	9	0 – 5.0	230/UC	136 047 L	136 032 D
A	3.0	G 1/4	0.23	9	0 – 5.0	24/UC	136 048 V	136 033 E
A	3.0	G 1/4	0.23	9	0 – 5.0	110/UC	136 049 W	136 034 F
A	3.0	G 1/4	0.23	9	0 – 5.0	230/UC	136 050 T	136 035 G
A	4.0	G 1/4	0.30	9	0 – 1.2	24/UC	136 051 Q	136 036 H
A	4.0	G 1/4	0.30	9	0 – 1.2	110/UC	136 052 R	136 037 A
A	4.0	G 1/4	0.30	9	0 – 1.2	230/UC	136 053 J	136 038 K
A	6.0	G 1/4	0.55	9	0 – 0.4	24/UC	136 054 K	139 890 W
A	6.0	G 1/4	0.55	9	0 – 0.4	110/UC	136 055 L	–
A	6.0	G 1/4	0.55	9	0 – 0.4	230/UC	136 056 M	139 891 K

EEx me II T4 approved

Seal material FPM, terminal box (not fused), single mounting only, without manual override

Circuit Function	Orifice DN [mm]	Port connection [inch]	Kv-Value (water) [m³/h]	Power consumption [W]	Pressure range [bar]	Voltage/Frequency [V/Hz]	Item-No. Body material	
							Brass	Stainless Steel
A	2.0	G 1/8	0.12	9	0 – 10.0	24/UC	139 909 D	139 897 R
A	2.0	G 1/8	0.12	9	0 – 10.0	230/UC	139 910 Z	139 898 S
A	2.0	G 1/4	0.12	9	0 – 10.0	24/UC	139 911 N	139 899 T
A	2.0	G 1/4	0.12	9	0 – 10.0	230/UC	139 912 P	139 900 G
A	2.5	G 1/8	0.16	9	0 – 8.0	24/UC	139 913 Q	–
A	2.5	G 1/8	0.16	9	0 – 8.0	230/UC	139 914 R	–
A	3.0	G 1/8	0.23	9	0 – 5.0	24/UC	139 915 J	139 901 V
A	3.0	G 1/8	0.23	9	0 – 5.0	230/UC	139 916 K	139 902 W
A	3.0	G 1/4	0.23	9	0 – 5.0	24/UC	139 917 L	139 903 X
A	3.0	G 1/4	0.23	9	0 – 5.0	230/UC	139 918 V	139 904 Y
A	4.0	G 1/4	0.30	9	0 – 1.2	24/UC	139 919 W	139 905 Z
A	4.0	G 1/4	0.30	9	0 – 1.2	230/UC	139 920 T	139 906 S
A	6.0	G 1/4	0.55	9	0 – 0.4	24/UC	139 921 Q	139 907 T
A	6.0	G 1/4	0.55	9	0 – 0.4	230/UC	139 922 R	139 908 C

Accessories (Medium Slow to Blow Fuses)

Voltage [V]	Power cons. [W]	Fuse rating [mA]	Item-No.
24	7	800	153 737 V
110	7	160	007 070 A
230	7	80	006 840 A
24	9	1000	007 077 V
110	9	250	153 732 Y
230	9	100	007 068 C

Compact Solenoid Valve Threaded Port G 1/8 – G 1/4; Sub-base Connection



Hazardous Areas

6013
Ex

Materials

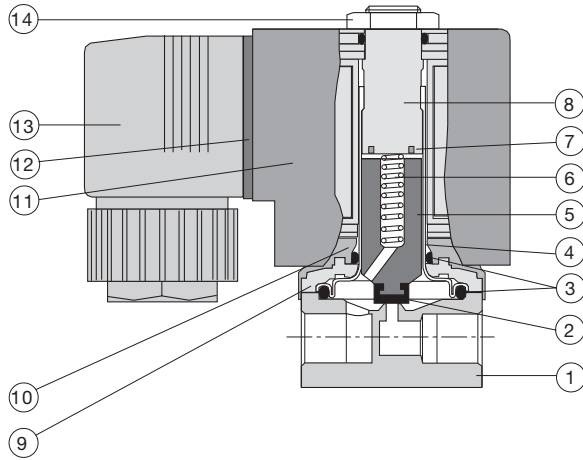

- | | |
|------------------------|--|
| 1 Valve body: | Brass,
SS 1.4305 (G1/8")
SS 1.4401 (G1/4") |
| 2 Plunger-seal: | FPM (Viton) |
| 3 O-rings: | FPM (Viton) |
| 4 Armature guide tube: | 1.4303 |
| 5 Plunger: | 1.4105 |
| 6 Spring: | 1.4310 |
| 7 Shading ring: | Cu (brass version)
Ag (stainless steel version) |
| 8 Stopper: | 1.4105 |
| 9 Flange: | Zn3 gl cC (surface) |
| 10 Bonnet: | Durethan BKV30H |
| 11 Coil: | PA (Polyamide) |
| 12 Flat seal: | NBR |
| 13 Cable plug: | PA (Polyamide) |
| 14 Locknut: | 9SMnPb28K (surface
Zn5glcA) |

Dimensions [mm]

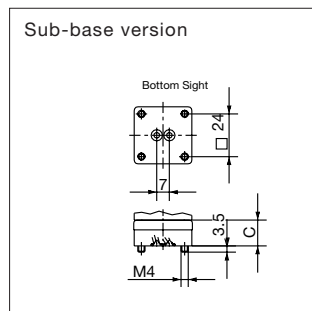
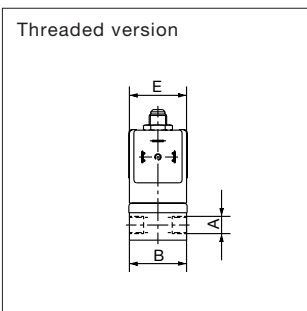
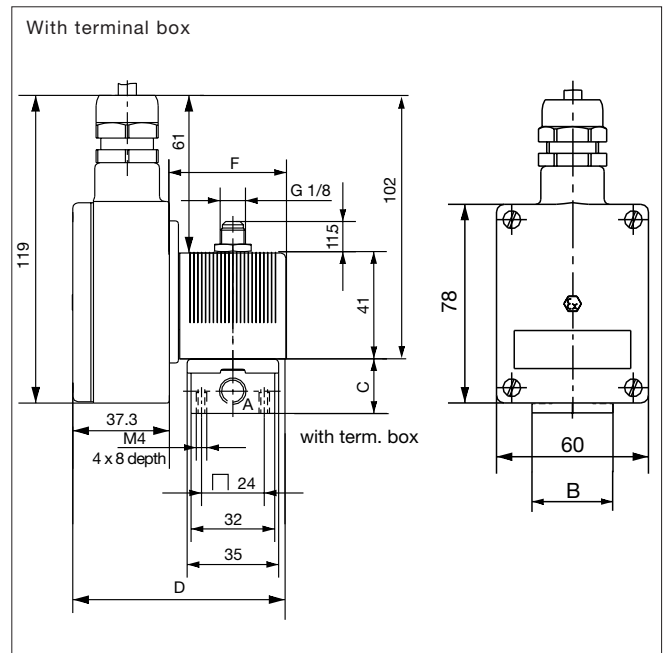
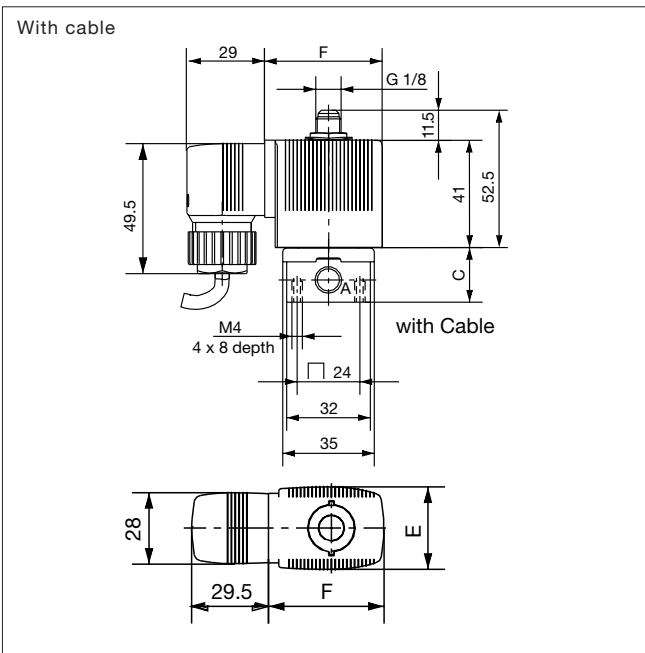

	Armature						Coil size
	A	B	C	D	E	F	
Threaded Port	1/8	32	20.8	32.6	32	45	32
	1/4	46	26.8	49	40	51	40
Sub-base	1/8	32	14.3	32.6	32	45	32

Compact Solenoid Valve Threaded Port G 1/8 – G 1/4; Sub-base Connection



Hazardous Areas

6013
Ex