

2/2-Way, G 1/2 - G 1, Flange (DN25)



Advantages/Benefits

- ▶ High reliability
- ▶ Erosion resistance
- ▶ Body materials:
Brass (threaded),
Grey cast iron (flange)
- ▶ Long service life of seal

Design/Function

The Type 406 is a servo-assisted on-off solenoid valve with servo piston operated in circuit function A, normally closed. When the pilot valve is closed, the pressure builds up above the piston via a bleed hole.

The piston closure is assisted by spring action. When the pilot valve opens, the pressure above the piston is relieved via a pilot channel.

Assisted by the pressure of the fluid, the piston moves upwards and opens the valve. A minimal differential pressure of 1 bar is required for complete opening.

Applications

- Fluids at high temperatures, such as hot air and steam
- Autoclaves (steam side)
- Ironing machines
- Steam cleaning systems
- Steam heating systems
- Large kitchens
- Plastic processing
- Injection moulding machines (thermal oil)

Solenoid Valve for steam and media at high temperatures up to 180 °C

Type 406

Technical Data

Circuit Function

A 2/2-way valve, normally closed, servo piston valve with 2-way pilot control

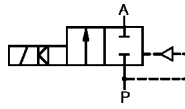

Body Material

- Threaded body of brass, seat 1.4303
- Flanged body of grey cast iron
- Internal parts of solenoid 1.4105
- Servo piston of brass

Specifications

Orifice DN [mm]	Kv-Value Water [m³/h]	QNm-Value Air [l/min]	Pressure Range [bar]		Weight [kg]	
			AC	DC	Threaded	Flanged body
13	3,7	4000	1-12	1-4	0,8	-
20	5,0	5400	1-12	1-4	1,2	-
25	10,0	10800	1-12	1-4	1,7	4,4
32	18,0	19400	1-12	-	2,9	-
40	18,0	19400	1-12	-	3,3	-

A min. differential pressure of 1 bar is required for complete opening.
All pressures quoted are gauge pressures with respect to the prevailing atmospheric pressure.

Operating Data (Valve)

Seal Materials/Fluids Handled/Temp.- Range

PTFE Neutral fluids, e.g. steam
0 to +180 °C

For more detailed information please refer to resistance chart (Leaflet-No. 1896009).

Max. ambient temperature +55 °C

Max. viscosity 21 mm²/s

Response times closing	DN	opening	
		[ms]	[ms]
	13-25	0,1 - 0,4	0,3 - 0,5
	32-40	0,2 - 1,2	1,0 - 3,0

Times measured at nominal pressure or at max. 6 bar operating pressure with water. They depend upon the orifice of the valve, as well as upon the pressure and viscosity of the handled fluid.

Operating Data (Actuator)

Operating voltages 240, 230, 110, 24 V/ 50 Hz
24 V/=

Voltage tolerance ±10 %

Power consumption AC DN 13-25 21 VA (inrush),
12 VA/8 W (hold)
DN 32-40 35-40 VA

(inrush) DC 16/VA 10 W (hold)
8 W

Duty cycle 100 % continuously rated

Cycling rate 10-60 c.p.m.

Rating with cable plug IP 65

Installation /Accessories

Installation as required, but preferably upright with solenoid system

Electrical connection

- cable plug for 7mm ø cable (supplied as standard)
- Silicone cable on request

Solenoid Valve for steam and media at high temperatures up to 180 °C

Type 406

Dimensions in mm

Ported Version

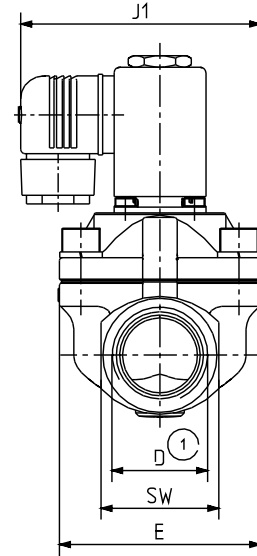
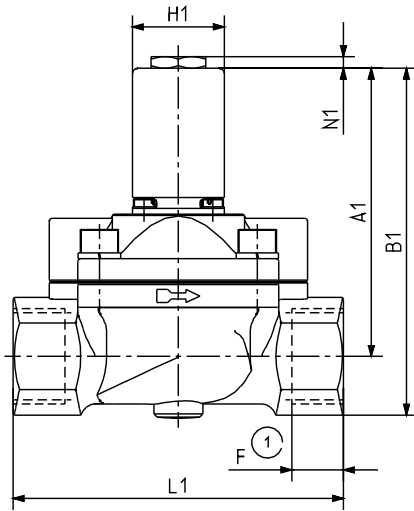

Flanged Version

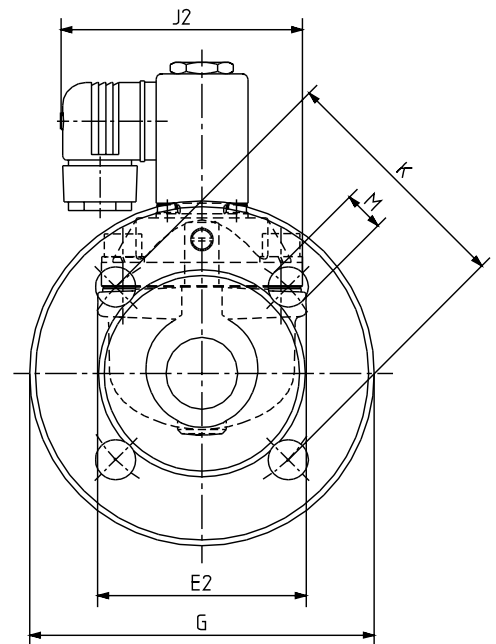
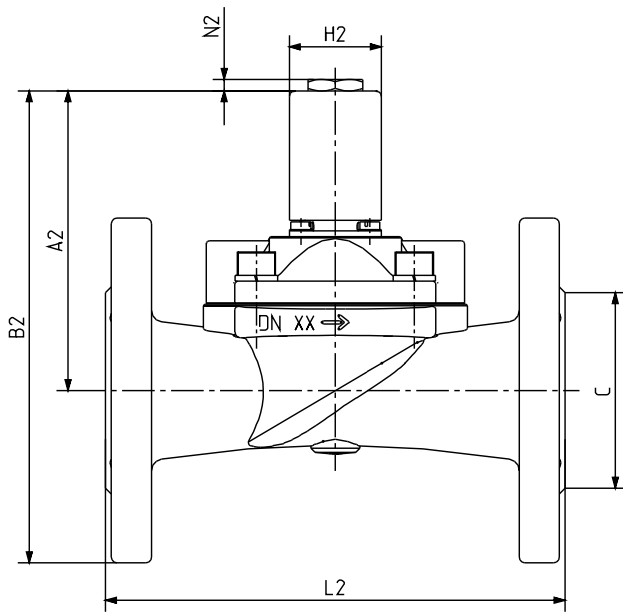

Orifice	Ported Version										Flanged Version										
DN	A1	B1	D1	F1	E1	L1	SW	J1	H1	N1	A2	B2	C	E2	G	L2	M	K	J2	H2	N2
13	95	109	G 1/2	14	40	65	27	69	32	4	-	-	-	-	-	-	-	-	-	-	-
20	95	111	G 3/4	16	60	100	32	79	32	4	-	-	-	-	-	-	-	-	-	-	-
25	100,5	121	G 1	18	70	115	41	84	32	4	105	165	68	73	120	160	14	85	86	32	4
32	141	166	G 1 1/4	20	85	126	50	96	40	9	-	-	-	-	-	-	-	-	-	-	-
40	145	175	G 1 1/2	22	85	126	60	96	40	9	-	-	-	-	-	-	-	-	-	-	-

Solenoid Valve for steam and media at high temperatures up to 180 °C

Type 406

Ordering Chart (Other Version on Request)

Circuit Function	Orifice DN [mm]	Flow Rate		Port Connection	Pressure Range [bar]	Body Material	Seal Material	Weight [kg]	Voltage/Frequency [V/Hz]	Order-No.
		Water Kv-Value [m³/h]	Air Q/Nn [l/min]							
A	13,0	3,7	4 000	G 1/2	1-12	Brass	PTFE	0,8	024/50	020 541 T
					1- 4	Brass	PTFE	0,8	024/=	019 310 A
					1-12	Brass	PTFE	0,8	110/50	023 200 H
									230/50	061 305 C
									240/50	021 690 S
	20,0	5,0	5 400	G 3/4	1-12	Brass	PTFE	1,2	024/50	019 818 U
					1- 4	Brass	PTFE	1,2	024/=	021 004 J
					1-12	Brass	PTFE	1,2	110/50	021 838 J
									230/50	061 303 A
									240/50	021 691 P
25,0	10,0	10 800	Flanged	1- 4	Cast iron	PTFE	4,4	024/=	078 255 J ¹⁾	
				1-12	Cast iron	PTFE	4,4	230/50	022 126 H	
			G 1	1-12	Brass	PTFE	1,7	024/50	021 440 X	
				1- 4	Brass	PTFE	1,7	024/=	019 983 J	
				1-12	Brass	PTFE	1,7	110/50	023 896 F	
								230/50	061 304 B	
								240/50	018 643 B	
32,0	18,0	19 400	G 1 1/4	1-12	Brass	PTFE	2,9	230/50	058 142 D	
40,0	18,0	19 400	G 1 1/2	1-12	Brass	PTFE	3,3	230/50	085 367 S	

¹⁾ Without cable plug