

Direct-acting, G 1/4, G 3/8, G 1/2



Advantages/Benefits

- ▶ Normally closed
- ▶ Body materials:
Brass, stainless steel
- ▶ Compact design

Design/Function

Type 256 is a direct-acting normally-closed plunger type solenoid valve. The valve is closed by spring action when de-energized.

When energized, the armature and seal are drawn against a spring - the valve opens.

The solenoid epoxy encapsulation efficiently dissipates the heat generated by the coil.

Applications

- Neutral gases and liquids
- Shut-off, dosing, filling, ventilating
- Control of washing lyes
- Welding machines, inert gas control
- Oil- and gas burners

bürkert
Easy Fluid Control Systems

Technical Data

Circuit Function

A 2/2-way valve,
normally closed

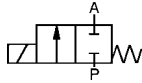

Body Materials

Brass body and seat (body A,B)
Brass body, seat 1.4112 (body C)
Body and seat 1.4410 (body A)
Valve internals 1.4105, 1.4301

Specifications

Orifice DN	Kv-Value Water	QNm-Value Air ¹⁾	Pressure Range ²⁾			Weight
			AC Liquids	Gases	DC Liquids and Gases	
[mm]	[m ³ /h]	[l/min]	[bar]	[bar]	[bar]	[kg]
3	0,25	270	0 - 22	0 - 22	0 - 10	0,60
4	0,50	540	0 - 12	0 - 16	0 - 6	0,60
5	0,65	700	0 - 6	0 - 12	0 - 2,5	0,60
6	0,80	860	0 - 4	0 - 8	0 - 2	0,60
8	0,90	970	0 - 1,5	0 - 2,5	0 - 0,5	0,60
10	1,50	1600	0 - 1	0 - 1,5	0 - 0,4	0,60
12	1,80	1930	0 - 0,5	0 - 1	0 - 0,1	0,60

¹⁾ Measured with 6 bar upstream pressure and 1 bar pressure drop across the valve at 20 °C. ²⁾ Also suitable for vacuum.

All pressures quoted are gauge pressures with respect to the prevailing atmospheric pressure.

Operating Data (Valve)

Seal Materials/Fluids Handled/Temp.- Range

NBR	Neutral fluids, e.g. compressed air, water, hydraulic oils, oils and fats without additives, town gas	-10 to +90 °C
EPDM	Oil- and fat-free fluids, e.g. hot water, alkaline washing and bleaching lyes	-40 to +130 °C
FPM	Hot air, oxygen, per-solutions, hot oils, oils with additives	-10 to +130 °C
Steel/ EPDM ⁴⁾	Oil- and fat-free fluids, e.g. hot water, steam ³⁾	-40 to +180 °C
Steel/ FPM ⁴⁾	Oil- and fat-free fluids, e.g. hot water,	-10 to +180 °C

For more detailed information please refer to resistance chart (Leaflet-No. 1896 009).

³⁾ Limited service life, when used with hot water or steam above +130°C. We highly recommend our Type 255.

⁴⁾ EPDM-or, FPM-O-ring.

Max. ambient temperature	+55 °C
max. viscosity	approx. 21 mm ² /s
Reponse times	opening
	AC 10-20 ms
	DC 20-80 ms
	closing
	AC 20-30 ms
	DC 20-30 ms

Times measured at an operating pressure of 6 bar with water. They depend on pressure and viscosity of the fluid handled.

Operating Data (Actuator)

Operating voltage	240, 230, 110, 24 V/ 50 Hz, 110 V/60 Hz, 110, 220 V/50-60 Hz 24 V/=
Voltage tolerance	±10 %
Power consumption	AC 35 to 40 VA (inrush), 16 VA/ 10 W (hold) DC ca. 12 W (hold)
Duty cycle	100 % continuously rated
Cycling rate	approx. 1000 c.p.m.
Rating	with cable plug IP 65

Installation / Accessories

Installation	as required, but preferably with solenoid system upright
Electrical connection	cable plug for 7 mm ² cable (supplied as standard)

Dimensions in mm

Body A

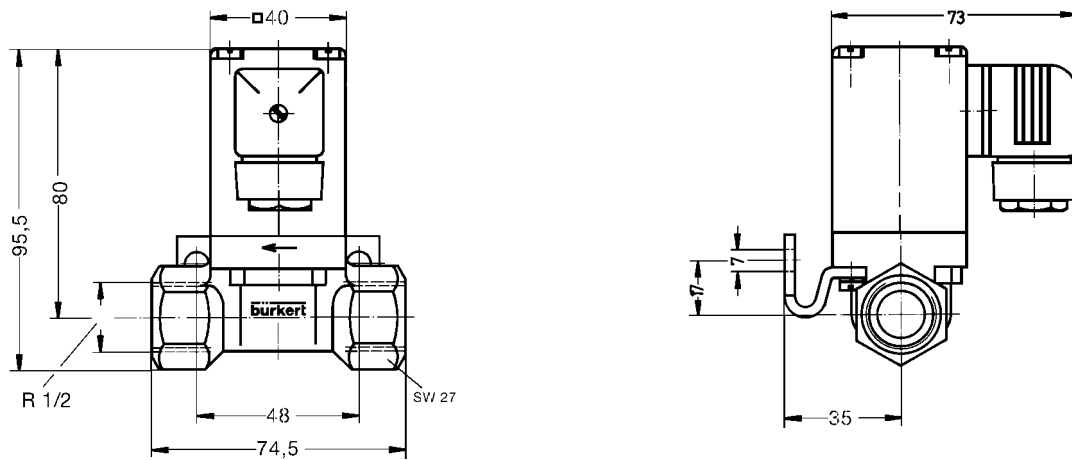

Body B

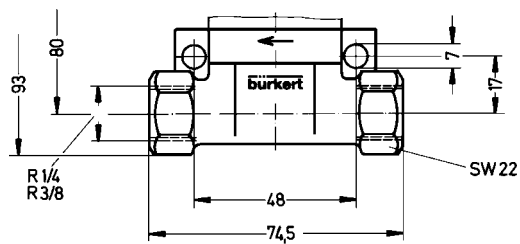

Body C

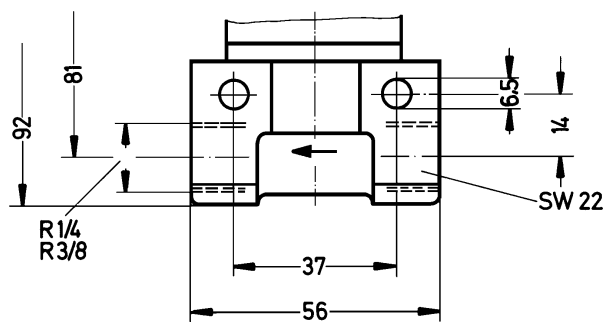

Ordering Chart (Other Versions on Request)

Circuit Function	Orifice DN [mm]	Flow Rate		Port Connection [mm]	Pressure Range ²⁾ [bar]	Body Material Body	Seal Material	Weight [kg]	Voltage/ Frequency [V/Hz]	Order-No.
		Water Kv-Value [m ³ /h]	Air ¹⁾ Qn [l/min]							
A	03,0	0,25	270	G 1/4	0-10	Brass C	NBR	0,60	024/=	043 336 Y
	04,0	0,50	540	G 3/8	0-16	Brass C	EPDM	0,60	230/50	056 456 W
				G 1/4	0-16	Brass B	NBR	0,60	024/50	055 184 M
						Brass C	NBR	0,60	024/50	054 218 D
					0- 6	Brass C	NBR	0,60	024/=	054 154 V
					0-16	Brass C	NBR	0,60	110/50	055 006 W
									230/50	054 896 N
									230/50-60	056 861 U
									240/50	040 937 U
				G 3/8	0-16	Brass C	NBR	0,60	024/50	054 660 L
					0- 6	Brass C	NBR	0,60	024/=	056 086 P
					0-16	Brass C	NBR	0,60	110/50	021 389 Y
									230/50	054 265 C
									240/50	054 380 C
				G 1/4	0-16	Brass B	FPM	0,60	230/50	055 631 U
				G 3/8	0- 6	Brass C	FPM	0,60	024/=	041 790 A
					0-16	Brass C	FPM	0,60	110/50-60	065 229 B
									110/60	078 585 W
									230/50	056 440 A
									230/50-60	057 462 V
				G 1/4	0- 6	Stainless A	FPM	0,60	024/=	018 452 U
				G 3/8	0- 6	Brass C	Steel/EPDM	0,60	024/=	045 236 W
					0-16	Brass C	Steel/EPDM	0,60	230/50-60	056 569 F
				G 1/4	0- 6	Brass C	Steel/FPM	0,60	024/=	041 688 G
				G 3/8	0- 6	Brass C	Steel/FPM	0,60	024/=	088 735 W
	05,0	0,65	700	G 1/4	0-12	Brass C	NBR	0,60	024/50	042 858 B
					0- 2,5	Brass C	NBR	0,60	024/=	057 334 U
					0-12	Brass C	NBR	0,60	110/50	058 697 A
									230/50	054 940 D
									240/50	066 385 Z
				G 3/8	0-12	Brass C	NBR	0,60	024/50	053 866 W
					0- 2,5	Brass C	NBR	0,60	024/=	054 220 B
					0-12	Brass C	NBR	0,60	110/50	044 503 S
									230/50	053 861 Z
									240/50	046 876 Z
						Steel/FPM		0,60	230/50	055 482 Q

¹⁾ Measured with 6 bar upstream pressure and 1 bar pressure drop across the valve at +20 °C.

²⁾ Also applies for technical vacuum.

 Limited pressure ranges for liquids (see chart on page 2).

