

32.5 mm Width; 18.0 mm Contact Clearance; 0 - 250 V

**Advantages/Benefits**

- ▶ (HL) High power electronic version for DC coils
- ▶ High inrush power and low holding power for critical temperature applications

**Design/Function****(HL) High power electronic version:**

This version is used to control DC coils of up to 72 W inrush and 4 W holding power.

Due to an integrated rectifier, this cable plug can be operated with both AC and DC voltage.

**Applications**

Plug-in connection for electrical devices and components, especially solenoid valves with lateral tag connectors.

For DC coils to be operated by (HL) high power electronic.

Tag configurations according to DIN 43650, form A.

## Technical data type 2511 – General

### Materials

Body	Polyamide PA
Cover (if transparent)	Polysulfone
Contacts	Brass, electro silverplated (Contact distance: 18 mm)

Isolation between cable plug & coil	NBR gasket 1.5 mm
--	-------------------

## (HL) High power electronic version

Voltage	24 - 48 V AC/DC 110 - 230 V AC/DC
Inrush power	max. 72 W
Inrush time	max. 400 ms
Operating temperature	-20 up to +70°C
Connections	
3 pole terminal strip	in the plug
Wire cross-section	max. 1.5 mm
Cable diameter	6 - 7 mm
Cable outlet	PG 16
Protection class	IP 65
Poles	2 pole and protective earth

### Function

The coil being operated with the cable plug type 2511 HL will be overdriven for approx. 400 ms on activation in order to ensure a high starting power. The electronic then switches to a much lower holding power.

## Dimensions [mm]

### (HL) High power electronic version

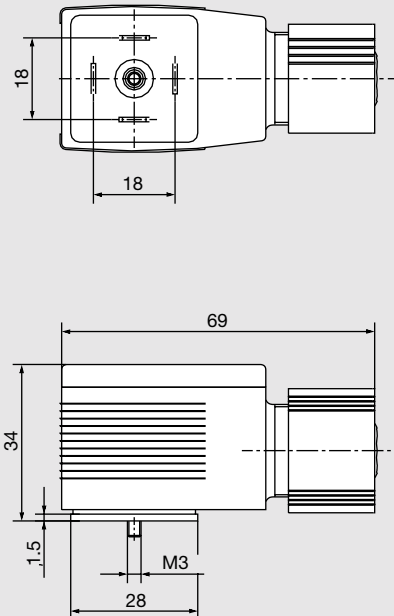

## Specifications - Ordering Chart

All cable plugs are supplied with mounting screw M 3.0 x 35 mm and gasket.

Circuitry	Voltage	Item No.
(HL) High power electronic	24.0 - 48.0 V AC/DC	138 307 G
(HL) High power electronic	110.0 - 230.0 V AC/DC	138 306 F

## Wiring Diagram

